



RS4 PRO 3

Setup Sheet - Setup Blatt - Feuille de réglage - セットアップシート

 4 - 7 May 2001
 Jonas Andersson
 Reedy Race 2001 - Snetterton, England

Front / Vorne / Avant / フロント

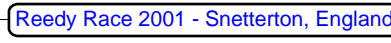
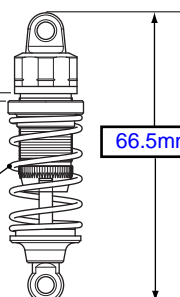

3.3mm

66.5mm

6851 HPI Navy

Black #A541 (3)

#6818 #1 #2 #3 #4 #5

#6158

Trinity 65wt



#3750 HPI 24mm Aero Dish

Pit shimizu Soft

Proline H-13

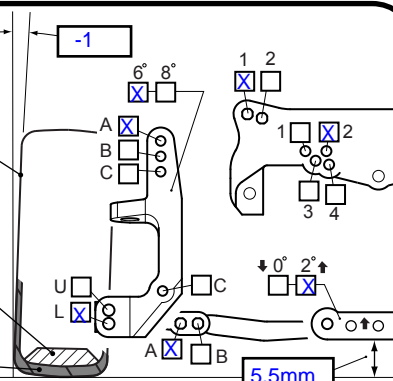

-1

6° 8°

1 2

A B C

U L

A B

5.5mm

Rear / Hinten / Arrière / リヤ

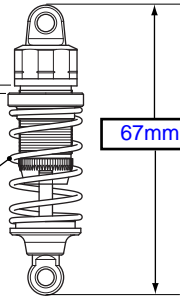

3.9mm

67mm

6851 HPI Navy

Black #A541 (3)

#6818 #1 #2 #3 #4 #5

#6158

Trinity 55wt



#3750 HPI 24mm Aero Dish

Pit Shimizu Soft

Proline H-13

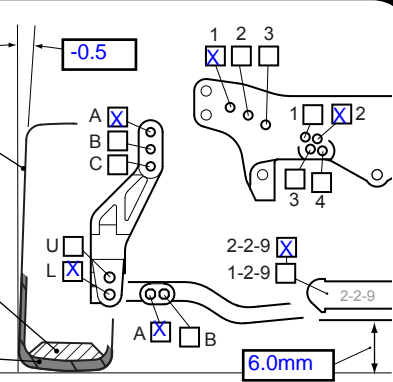

-0.5

1 2 3

A B C

U L

A B

2-2-9

1-2-9

2-2-9

6.0mm

Top / Oben / Haut / 上

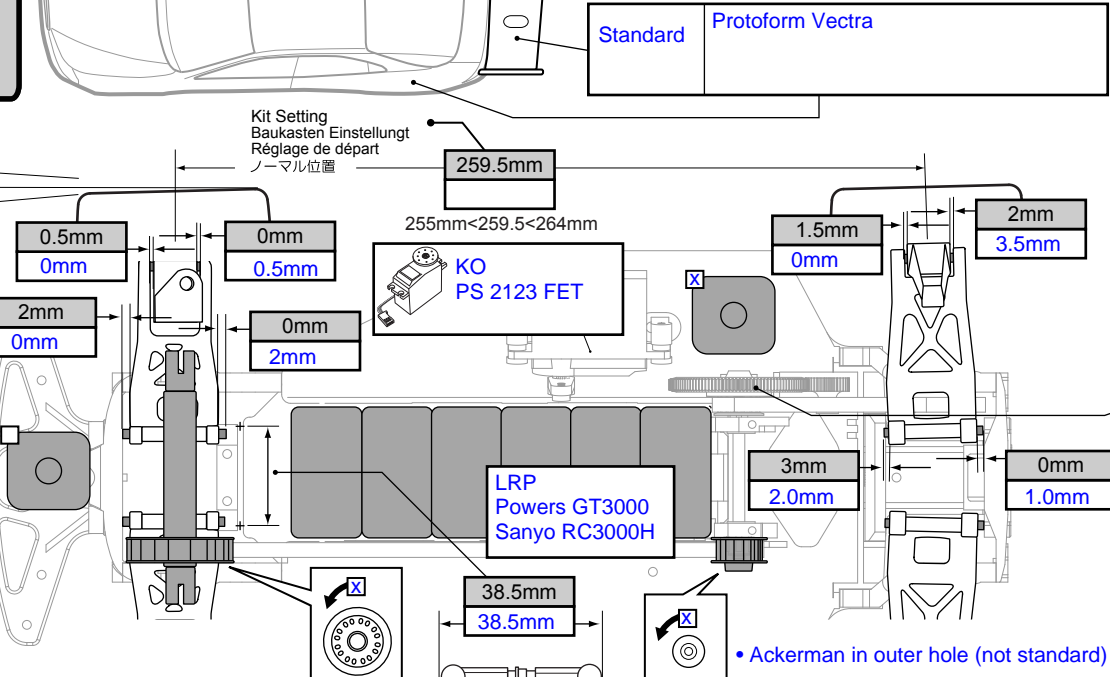

Standard Protoform Vectra

Kit Setting
Baukasten Einstellung
Réglage de départ
ノーマル位置

259.5mm

255mm < 259.5 < 264mm

KO PS 2123 FET

LRP Powers GT3000 Sanyo RC3000H

38.5mm

38.5mm

• Ackerman in outer hole (not standard)

X-Max

Purple

Red

X-Max

LRP Fusion 12 x 3

78

30 x 2.25 = 5.85

LRP Quantum 3-0-0

Notes / ノート

Tyre Additive: LRP Top Traction, Apply 1 Hour before start and let dry.
 Inserts "Shortened" 6 - 7 mm to fit better in the tyres.
 Used rod from center of battery bar to the rear to stiffen the chassis and loosen front belt.
 Made 'A' Final

Run / レース結果	Run/ Qualifier/ Main	Laps	Time	Fastest Lap
				13.93 seconds

