

The Wheelie Bar allows you to ride perfect wheelies for as long as you want.
Die Wheelie-Bar erlaubt es perfekte Wheelies zu machen – so lange, wie man will.
La barre anti-cabrage vous permet de rester parfaitement en position de cabrage aussi longtemps que vous le voudrez.
安定した長距離ウイリー走行が可能になります。

Equipment Needed
Benötigtes Zubehör
Équipement nécessaire
必要な工具

Z950
Cross Wrench
Kreuzschlüssel
Clé en croix
ミニクロスレンチ

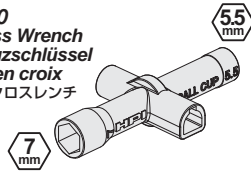

Allen wrench
Inbusschlüssel
Clé Allen
六角レンチ

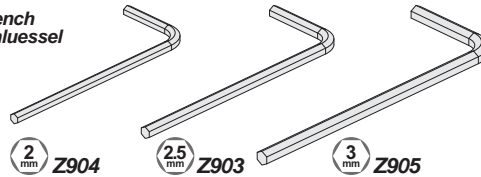

1 Wheelie Bar Assembly
Wheely-Bar Montage

Montage de la barre anti-cabrage
ウイリーバーの組立て

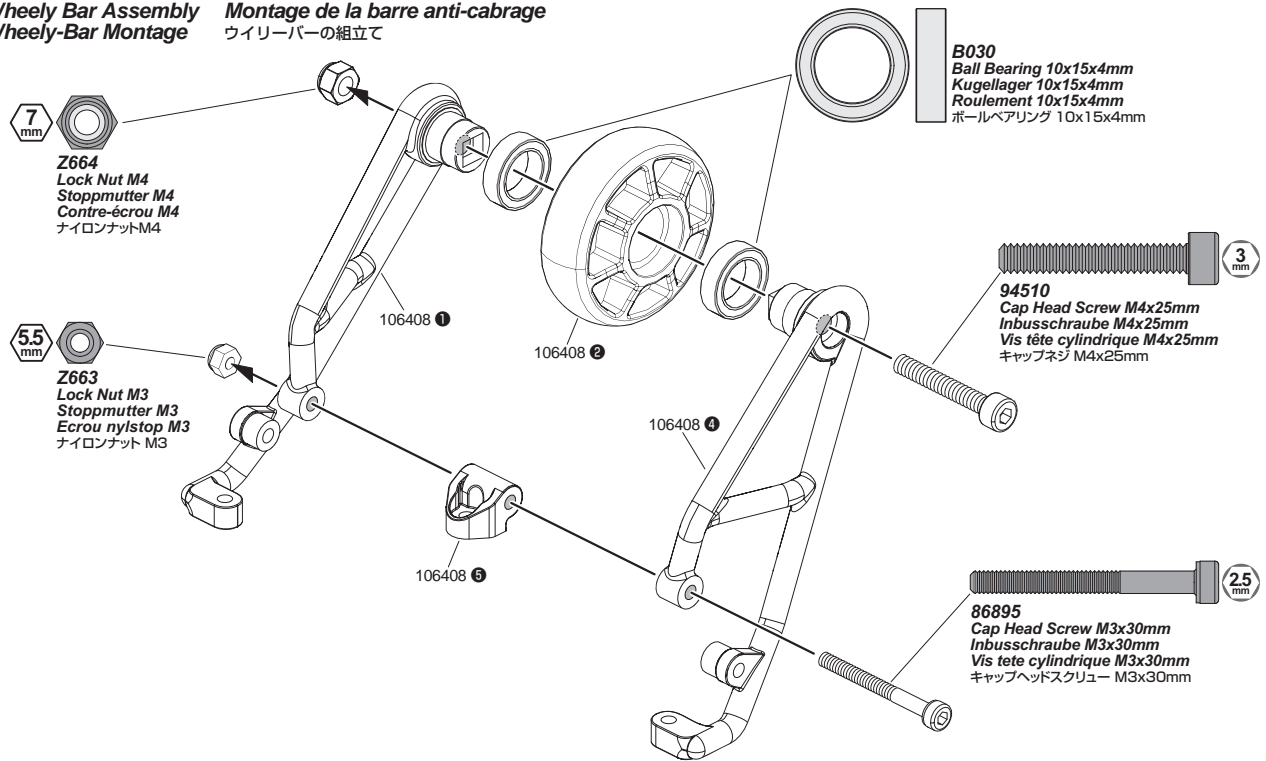

2 Screw Removal
Schrauben-Demontage

Retrait des vis
ネジの取外し

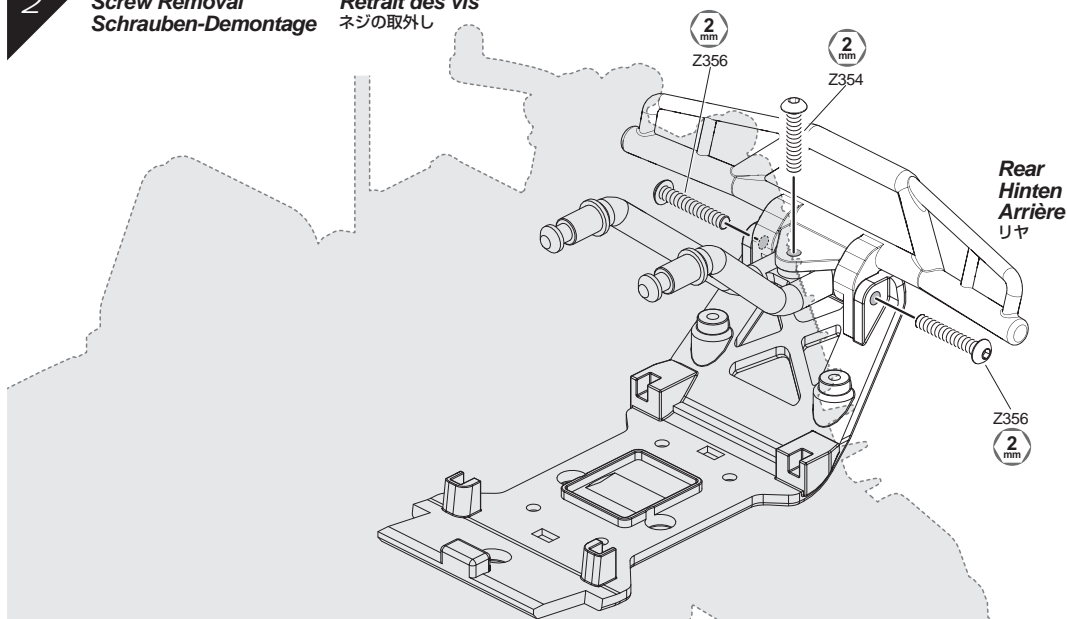

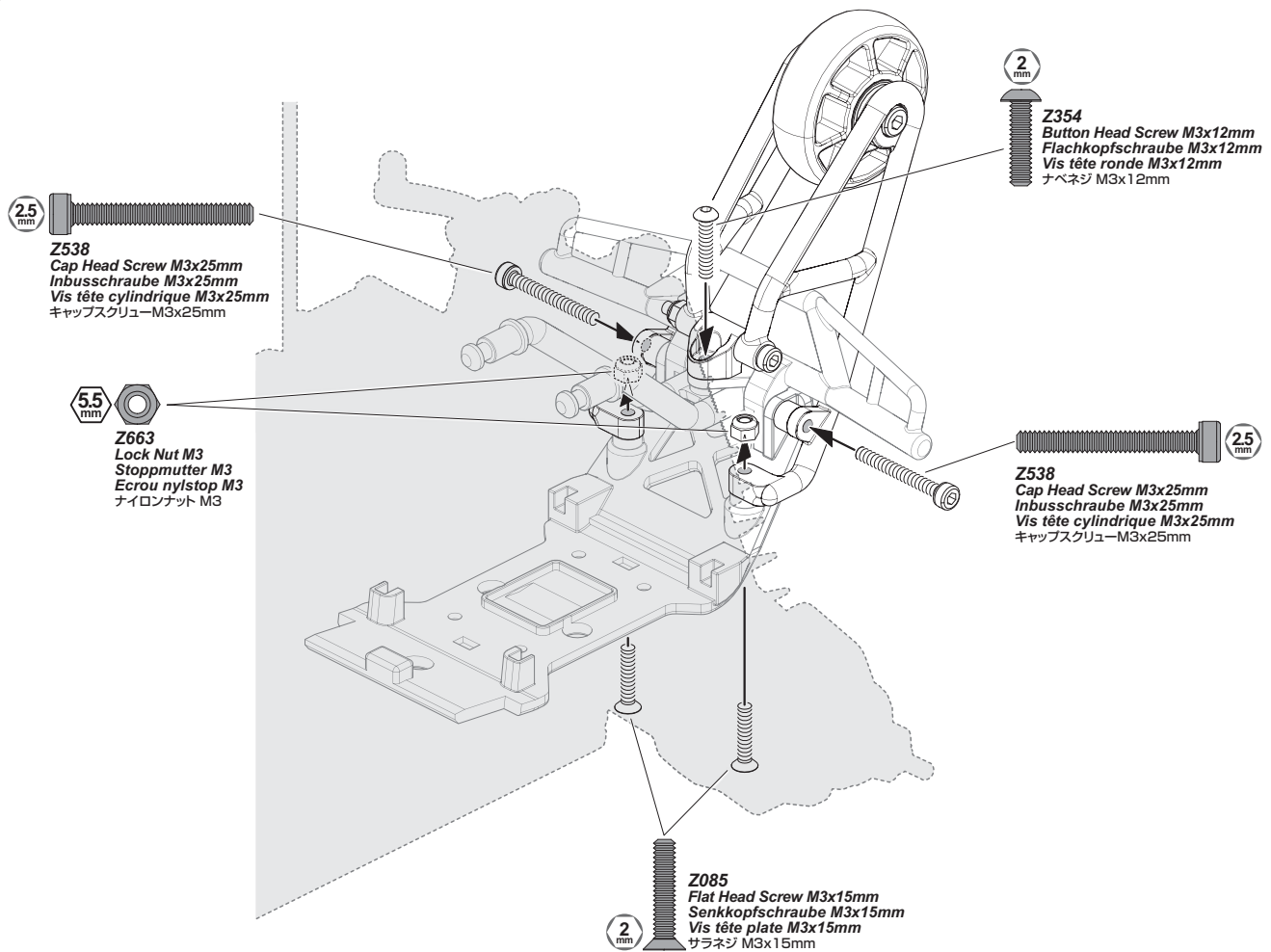

Spare Parts Ersatzteile Pièces détachées スペアパーツ								
Part # Nummer Numéro 品番	Qty. Anzahl Qté. 入数	Description Beschreibung Description 説明	Part # Nummer Numéro 品番	Qty. Anzahl Qté. 入数	Description Beschreibung Description 説明	Part # Nummer Numéro 品番	Qty. Anzahl Qté. 入数	Description Beschreibung Description 説明
86895	x10	CAP HEAD SCREW M3x30mm INBUSSCHRAUBE M3x30mm VIS TÊTE CYLINDRIQUE M3x30mm キャップヘッドスクリュー M3x30mm	Z085	x10	FLAT HEAD SCREW M3x15mm (HEX SOCKET) SENKKOPFSCHRAUBE M3x15mm (INBUS) VIS TÊTE PLATE M3x15mm (SIX PANS CREUX) サラネジ M3x15mm (六角ソケット)	Z663	x6	LOCK NUT M3 STOPPMUTTER M3 ECROU NYLON M3 ロックナット M3
94510	x10	CAP HEAD SCREW M4x25mm INBUSSCHRAUBE M4x25mm VIS TÊTE CYLINDRIQUE M4x25mm キャップネジ M4x25mm	Z354	x10	BUTTON HEAD SCREW M3x12mm (HEX SOCKET) FLACHKOPFSCHRAUBE M3x12mm (INBUS) VIS TÊTE RONDE M3x12mm (SIX PANS CREUX) ナベネジ M3x12mm (六角ソケット)	Z664	x4	LOCK NUT M4 STOPPMUTTER M4 ECROU NYLSTOP M4 ナイロンナットM4
B030	x2	BALL BEARING 10x15x4mm KUGELLAGER 10x15x4mm ROULEMENT A BILLES 10x15x4mm ボールベアリング 10x15x4mm	Z538	x6	CAP HEAD SCREW M3x25mm INBUSSCHRAUBE M3x25mm VIS TÊTE CYLINDRIQUE M3x25mm キャップネジ M3x25mm			